

SENSORS FOR MEASURING OF OXYGEN CONCENTRATION AND OF TEMPERATURE TYPE CSOT 63-66

Instruction manual for operation and maintenance

▪ CONTENTS

1. Range of application	page 2
2. Delivery size	page 3
3. Putting into operation	page 3
4. Measuring	page 3
5. Sensor maintenance	page 4
6. Spare parts	page 4
7. Basic properties of the sensor	page 5
7.1. Function of the sensor	page 5
7.2. Dependence of sensor current on the motion velocity	page 5
of the measured sample	
8. Construction of the sensor	page 6
9. Technical data	page 6
10. Storage	page 7
11. Protecting the environment	page 7

Explanatory notes

In this manual, following signs are used:



Ignoring this warning may lead to a damage of the sensor or to a wrong measuring, (control).



Ignoring this warning may lead to an irreversible damage of the sensor, of the technological equipment or to a jeopardy of safety and security of persons.



Information for manipulation with wastes

CAUTION

Manipulate with the sensors may only a person with adequate qualification, familiar with their function and maintenance.

The use of the sensors beyond the frame determined by this manual is inadmissible.

As long as the sensor is used for an automatic control, it is necessary to provide a regular check-up of its function. It is essential to realize, that by a failure of the sensor the dosing element can be maximally opened or fully closed and this may cause serious problems in the operation of the controlled technology.

The automatic control is irregular even during the cleaning or another manipulation with the sensor (replacement of the membrane head).

For the sensors, only the original spare parts delivered by the manufacturer may be used.

The function of sensors must be checked-up regularly. The time intervals between the individual check-ups will arise from the operational experience.

Greatest possible care was used on the correctness of the information in this manual. If errors should be discovered nevertheless, INSA s.r.o. is pleased to be informed about it.

▪ 1. RANGE OF APPLICATION

The sensors **CSOT 63-66** are optical oxygen sensors, intended for measuring of oxygen concentration in liquid and gaseous media and for temperature measuring at the same time. The sensors are intended for direct connection to the input circuits of the measuring and controlling systems provided with the analogue inputs 4 – 20 mA and also for connection to  process controller **MKT 66**.

The sensors are used e.g. for measuring of oxygen concentrations at the biological WWTPs (Waste Water Treatment Plants), for measuring in surface water as well as ground water, in water treatment processes, at fish breeding plants etc.

▪ 2. DELIVERY SIZE

A part of the sensor delivery are following accessories:

Instruction manual for operation and maintenance

▪ 3. PUTTING INTO OPERATION – REPLACEMENT OF MEMBRANE HEAD

When putting the sensor into operation or replacing the worn off membrane, observe following procedure (Fig.1):

If necessary clean the sensor thoroughly.

1. Unscrew the spherical cover of membrane head (5) firstly.

2. Unscrew the old membrane head (4) - (normal nuts against the clockwise direction) from the sensor body (1).



3. Screw the new sensor head again on the sensor with delicacy but **firmly**. Membrane head must fit perfectly on sensor body to be sealing effect guaranteed.

4. We connect sensor according to fig. 2. or fig 3. (MKT 66).



The sensor must not be dipped in water without membrane head.

▪ 4. MEASURING

Immediately after connecting the sensor to the measuring instrument, sensor is ready to measure. Nevertheless electronic placed inside of the sensor needs some minutes for temperature stabilisation. During this time sensor signal fluctuates a little.

Thermistor which is utilized for temperature measuring and for signal correction is placed in a metallic block. The sensor must be dipped min.10 mm above the brim of block, during the measuring.



The water temperature must not exceed 50 °C.

▪ 5. SENSOR MAINTENANCE

During the operation, the separating membrane ages – its mechanical properties deteriorate. The ageing appears in a growth of idle current, by a drop of dynamic properties and by instability of sensor signal. If the measurement is instable it is necessary to replace membrane head. The procedure for replacement of the membrane head is described in section 3.

In order to secure a trouble-free operation, it is convenient to replace the membrane after approx. 12 months from installation (as long as no mechanical damage occurs). When using the sensor in relatively stable conditions (e.g. at activation of biological wastewater treatment plants), this period lengthens up to 24 months.

A contaminated membrane surface can be cleaned by careful wiping with wetted cotton. In case the membrane is covered with a layer of mucous microorganisms (e.g. when used for the activation of WWTP), which cannot be removed by a slight wiping, it is appropriate to dip the sensor into a 1%-solution of natrium azide for few minutes and wipe afterwards.

As long as no break of the membrane and no contamination of the inner space of the sensor occurred, the replacement of the membrane head is to be performed according to the procedure described in section 3. The detection system does not need any care.

Possible replacement of membranes in the membrane head provides the manufacturer of the sensor.



As long as a failure of the membrane occurs and the inner space of the sensor gets contaminated, it is unavoidable to treat the sensor, which the manufacturer of the sensor or his accredited service shop have to do.

▪ 6. SPARE PARTS

Membrane head MH 21 O ₂	(4)
Membrane head sealing Φ 10x1,8	(3)
Spherical cover sealing Φ 17x1	(2)

▪ **7. BASIC PROPERTIES OF THE SENSOR**

▪ **7.1. Function of the sensor**

Basic element of the sensor is luminophore layer. The layer is separated from the measured environment by a separation membrane, permeable for oxygen (but also for other gases, e.g. H₂S, SO₂, CO₂, Cl₂), but impermeable for ions and most of adsorptive impurities, usually present in the solutions, which would interfere in the presence of the membrane or disturb the oxygen measurement.

The luminophore is actuated by blue light. The blue light generates in luminophore layer red light (luminescence), intensity and time of decay of which depends on concentration of the oxygen. In the presence of oxygen is intensity and time of quenching low, with falling concentration both parameters rise.

This process follows following (Stern-Volmer) relationship:

$$I_0 / I = 1 + K_{sv} \cdot p_{O_2}$$

Where: I_0 is intensity of luminescence in the absence of oxygen

I is intensity of luminescence in the presence of oxygen of partial pressure p_{O_2}

K_{sv} is Stern-Volmer constant depending on the properties of luminophore and immobilizing layer

p_{O_2} is actual partial pressure of oxygen

The sensor signal is affected by temperature, noticeably. The temperature dependency must be balanced out in the measuring instrument, provided the measuring is not made by a constant temperature (with a deviation $\pm 0,1^\circ\text{C}$). In order to be able to make a sufficient offset, an NTC - thermistor is integrated in the **CSOT 63-66** sensors.

▪ **7.2. Dependence of current signal of the sensor on velocity of motion of measured ambience**

Signal of an optical sensor – in contrast to electrochemical sensor - does not depend on the velocity of the measured medium.

▪ **8. CONSTRUCTION OF THE SENSOR**

The blue light is generated by the blue LED, which is together with red light detecting diode placed in the top of the sensor. Both diodes are covered by membrane head containing luminophore and separation membrane and connected to electric circuits placed in the body of the sensor.

The cable of the sensor is led directly to input terminals of process controller or interconnection terminal boxes

The thermistor is placed in the metallic part of the sensor body (2). While working with the sensor, we have to see, that the sensor is dipped in the measured liquid at least 10 mm above the brim of the metallic part.

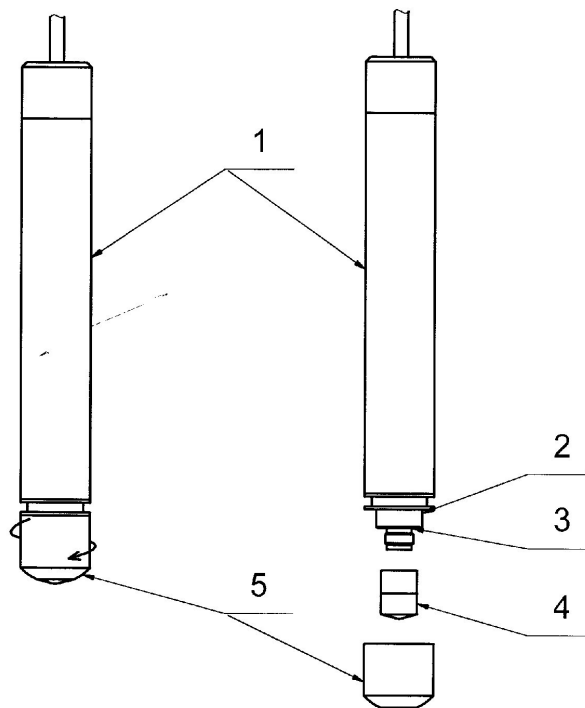

Fig. 1 Sensor CSOT 63-66 – exchange of membrane head

▪ **9. TECHNICAL DATA**

Category of Sensor	optical sensor, measuring of dynamic oxygen quenching
--------------------	--

Measuring Range	0,1 to 20,0 mg/l, 1 to 200%
Sensitivity	0,01 mg/l, 0,1%
Dynamic Properties	T ₉₀ - approx. 70 s
Output	galvanically isolated, 2x4,5 - 20 mA
Supply voltage	12,0 to 28,0 V=
Supply current	max 45 mA
Pressure	max 0,6 MPa
Operating Temperature	0 to 50°C
Storage temperature	-10 to 60°C
Dimensions	Ø30 mm x 240 mm
Material	Polyester, EPDM, PTFE, silicone, stainless steel
Minimum Flow Rate	0 mm/s
Cable specification	two core, unshielded cable, outer sheath polyurethane, outer diameter 6,3 mm
Cable length	5 or 10 m standard, other lengths on request
Cover	IP 68

▪ 10. STORAGE

The sensor can be kept dry and clean for several months to one year in a dust-free ambience without any chemical exhalations.

▪ 11. PROTECTING THE ENVIRONMENT

In accordance with the EC guideline 2002/96/EG sensors have to be supplied to a separated collection for electrical and electronic devices. They may not be supplied to the unsorted settlement waste.



The sensors don't contain recycled materials.

For the fabrication of the sensors stainless steel, silicone materials, PVC and polypropylene is used.

Oxygen sensor can be supplied directly from the external device. No other power supply is needed.

CSOT 63-66-terminal	External device input terminal - function
1 – white cable shoe	(4,5 to 20 mA → 0 to 20 mg/l) - Oxygen
2 – yellow cable shoe	(+)
3 – brown cable shoe	(4,5 to 20 mA → 0 to 50°C) - Temperature

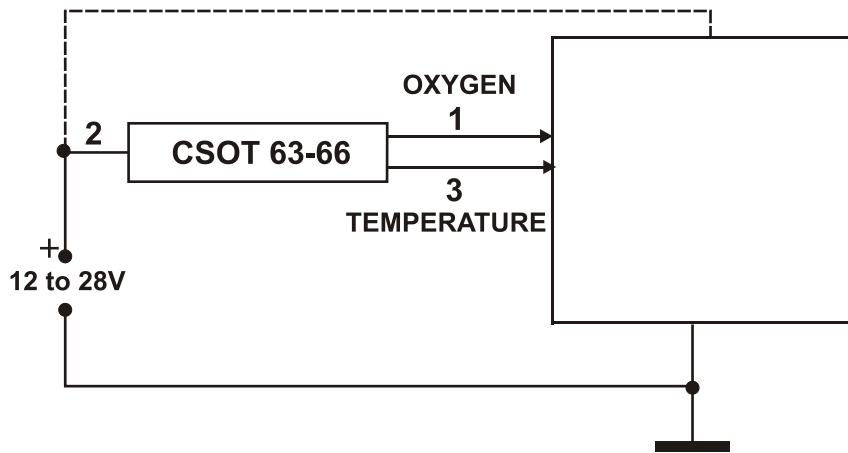

Fig. 2 Sensor connection to external device